

THICKNESS: 8" FOR LOCAL ROADS AND 6" FOR PRIVATE PARKING LOTS  
 CROSS SLOPE: FOR ROADWAYS, 1/4"/FT; FOR PRIVATE PARKING AREAS, MINIMUM 0.50%  
 MEASURED FROM THE RECEIVING INLET, GUTTER, OR FLUME TO HIGH POINT

TYPICAL PAVEMENT SECTION

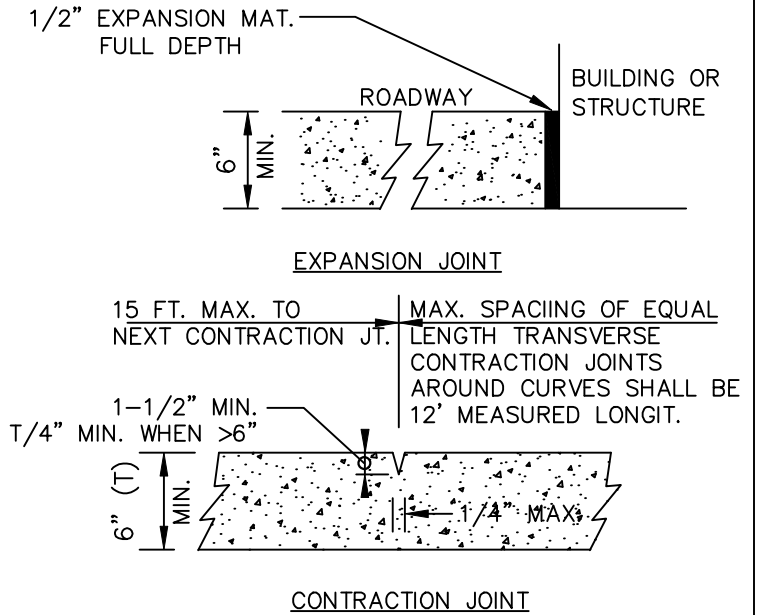
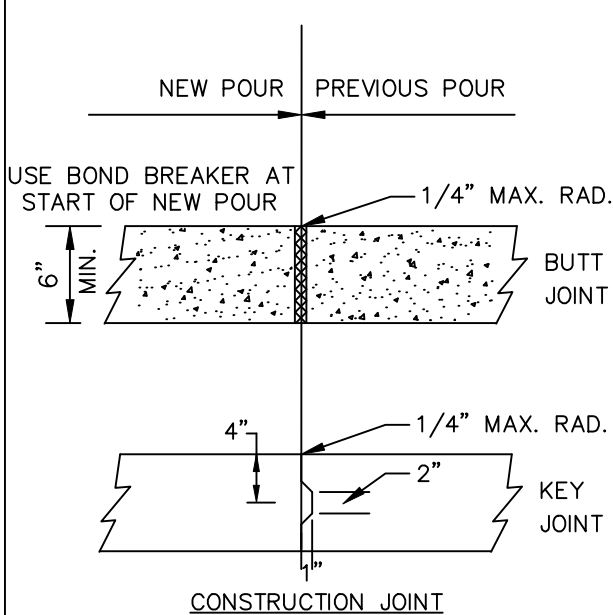

NOTES:

1. CONTRACTION JOINTS MAY BE HAND FORMED, SAWED OR CONSTRUCTED WITH A 1/4" PRE-MOLDED FILLER JOINT. JOINTS MUST BE SAWED BETWEEN 4 AND 18 HOURS AFTER CONCRETE HAS BEEN PLACED.
2. EXPANSION JOINTS TO BE PLACED BETWEEN STRUCTURE AND CURB AND AT ANY PERMANENT STRUCTURE ABUTTING OR WITHIN THE PAVED AREA, INCLUDING SIDEWALKS. USE OF WOOD IS NOT ACCEPTABLE.
3. FINAL DETERMINATION OF CONSTRUCTION JOINT SELECTION AND APPLICATION SHALL BE MADE BY THE ENGINEER OF RECORD BASED ON PROJECT REQUIREMENTS AND LOCATION.
4. CONSTRUCTION JOINTS WITHIN THE SLAB AREA SHOULD NOT CONTAIN PRE-MOLDED EXPANSION JOINT FILLER.
5. CONCRETE PAVEMENT CONSTRUCTION SHALL BE IN ACCORDANCE WITH ACI PUBLICATION 330R-87.



STANDARD CONSTRUCTION DETAIL  
 CONCRETE PAVEMENT DETAILS

REV. 12/18

FILE NAME:

R14.DWG

DETAIL REF:

**R-14**